

EUROPEAN PATENT OFFICE

Patent Abstracts of Japan

PUBLICATION NUMBER : 06329429
PUBLICATION DATE : 29-11-94
APPLICATION DATE : 24-05-93
APPLICATION NUMBER : 05121067

APPLICANT : NIPPON GLASS FIBER CO LTD;

INVENTOR : MAEDA KOJI;

INT.CL. : C03B 37/005

TITLE : PRODUCTION OF FLAKY GLASS AND APPARATUS THEREFOR

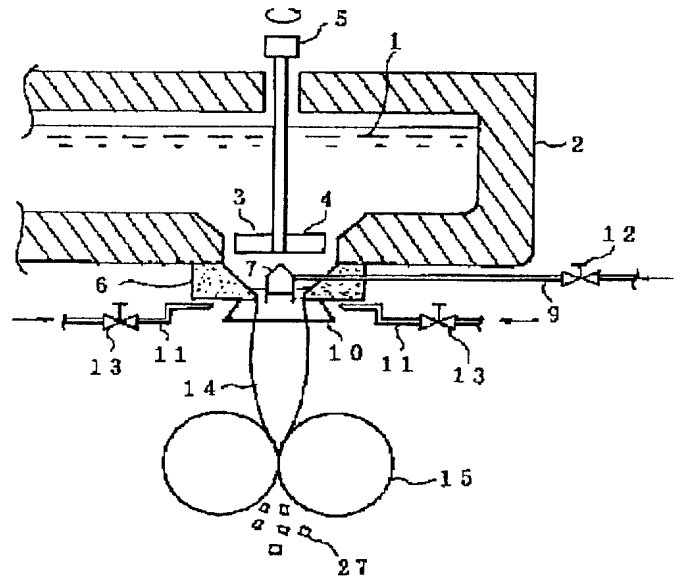

ABSTRACT : PURPOSE: To produce thin-wall flaky glass having a uniform thickness.

CONSTITUTION: Molten glass taken out of a molten glass discharge port 3 of a refractory furnace vessel 2 into a hollow form is formed into a balloon with air blown from a blowing nozzle 7, pulled with pull rollers 15, etc., and pulverized to provide desired flaky glass 27. The degree of air-cooling is changed by respectively changing the flow rates of air, used for allowing a molten glass stream to cool and blown from plural air blowoff nozzles 11 on a flange 10 for heat radiation on the periphery of the outlet of a guide part (bushing 6) having an opening in the center for guiding the molten glass stream in the lower part of the molten glass discharge port 3. The temperature distribution in the circumferential direction of the molten glass stream can be controlled to cancel the nonuniformity of the temperature. As a result, the uniformization of the thickness of the molten glass stream can be accomplished.

COPYRIGHT: (C)1994,JPO